

BINDING PRODUCTS

For All Your In-Office Binding Needs®

WR-2500E



www.bindingproducts.com

(Also see our demo video at: <https://www.youtube.com/watch?v=nIHPxXTZJd4>)

Thank you for your purchase of the WR-2500E electric 2:1 and 3:1 wire binding machine.

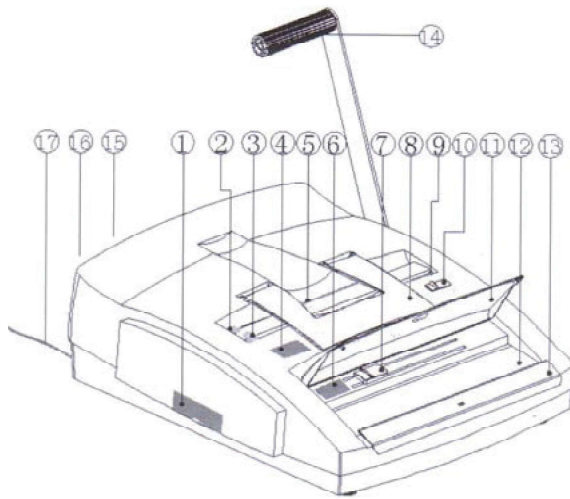

1. Waste Tray
2. 3:1 Wire Margin Guide
3. 2:1 Wire Margin Guide
4. Wire Comb Measuring Guide
5. 3:1 Wire Punch Throat
6. Sheet Measuring Guide
7. Wire Diameter Guide
8. Paper Support Tray
9. 2:1 Wire Punch Throat
10. Punch Switch
11. Dust Cover
12. Wire Closer
13. Wire Hanger
14. Handle
15. Fuse
16. Power Switch
17. Power Cord

General Precautions:

1. Read the instructions carefully and thoroughly prior to using the machine.
2. Avoid punching metal objects such as staples or paper clips. This may jam the machine.
3. Keep fingers away from the punching throat to avoid injury.
4. Empty waste tray frequently for best results.
5. Ensure that the rating plate on the machine is appropriate for your electricity supply.

Assembly:

1. Place machine on flat surface.
2. Insert handle onto the handle axle on the right side of the machine. (See Fig. 1.1)
3. Fasten the handle into place with the screw provided.

Fig. 1.1

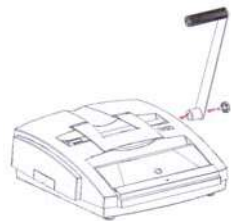

Getting Started:

1. Plug the power cord into an electrical outlet.
2. Turn the power switch on.

Punch:

1. Lift the paper support tray up. (See Fig. 2.1)
2. Use the paper margin guide to properly align papers. If you are using 2:1 wire, use the 2:1 wire margin guide; if you are using 3:1 wire, use the 3:1 wire margin guide.
3. Insert document into appropriate punch throat. If you are using 2:1 wire, use the 2:1 wire punch throat. If you are using 3:1 wire, use the 3:1 wire punch throat. (Max. 20 sheets of 20 lb paper). (See Fig. 2.2)
4. Slide the punch switch to the right. (See Fig. 2.3)
5. Remove punched document

Fig. 2.1



Fig. 2.2



Fig. 2.3

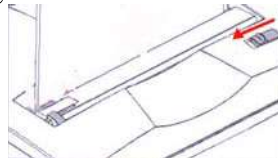

Bind:

1. Use the wire diameter guide to determine the appropriate size wire to be used for your document. It can also be determined using the following table. **Note: The standard is 20lb paper.**

Wire Size	1/4	5/16	3/8	7/16	1/2	9/16	5/8	3/4	7/8	1
Max # of Sheets	45	60	75	85	100	120	135	165	180	200

2. Place wire open side up on the wire hanger.
3. Thread pages onto the wire hanger. (See Fig. 3.1)
4. Lift the wire closing handle so it is in the vertical or upright position.
5. Place the document in the wire throat so that the side to be bound enters first. (See Fig. 3.2)
6. Hold the document steady and pull down on the wire closing handle to bind the document. (See Fig. 3.3)
7. Remove the bound document.

Fig. 3.1

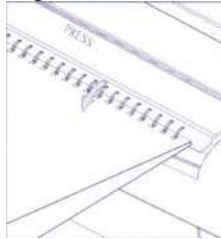

Fig. 3.2

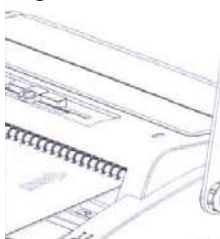

Fig. 3.3



Emptying the Trash:

1. If you hear an alarm, it is necessary to empty the machine. **Note: The machine will not function unless the bin is emptied.**
2. Slide the waste tray out of the unit.
3. Empty the waste tray.
4. Slide the waste tray back into the machine.

Technical Specifications

Punching Functions	Multiple
Punch Style	3:1 & 2:1 Wire
Punch	Electric
Punch Capacity	20 sheets (20 lb paper)
Operating Method	Punch-Electric Bind-Manual
Punch Depth Control	No
Max. Page Size	Letter
Bind Capacity	1" (28 mm)
Sheet Capacity	200
Margin Guide	Yes
Edge Guide	Adjustable
Paper Load	Vertical
Disengageables	N/A
Machine Dimensions	18" x 2.25" x 7.5"
Box Dimensions	20.5" x 11" x 24.5"
Shipping Carton Dimensions	26" x 27" x 13"
Net Weight	45 lbs
Gross Weight	59 lbs

www.bindingproducts.com

(Also see our demo video at www.bindingproducts.com)